

Cambridge

Designed by the Berroco Design Team / Skill level: Intermediate



FINISHED MEASUREMENTS

Bust: 37 (40, 43, 46, 49, 52, 55, 58, 61, 64)"

Length: 23 (23, 23½, 23½, 24, 24, 24½, 24½, 25, 25)"

Shown in size 40". Recommended ease: 2-4" positive ease.

YARN

BERROCO ULTRA WOOL FINE (100 grs): 4 (4, 5, 5, 6, 6, 6, 7, 7, 7) balls #53153 Heather (MC) and 2 (2, 3, 3, 3, 3, 4, 4, 4) balls #53108 Frost (CC)

NEEDLES and NOTIONS

Knitting needles, size 5 (3.75 mm) or size to obtain gauge

16" circular needle, size 3 (3.25 mm)

2 double-pointed needles (dpns), size 3 (3.25 mm)

Waste yarn for provisional cast-on and to hold stitches

GAUGE

26 sts and 32 rows = 4" in St st on larger needles

To save time and ensure accurate measurements, take time to check gauge.

Berroco
Ultra® Wool Fine

Find this Yarn 



BERROCO®



www.berroco.com

We recommend using yarns called for in our instructions. Every effort has been made to ensure that directions contained in this book are accurate and complete, however errors do occur. We cannot be responsible for variance of individual knitters, human or typographical errors.

All pattern PDFs are updated when corrections are made. In the event of finding an error, please make sure you've downloaded the most recent version.

BACK

With straight needles, using MC, cast on 120 (130, 140, 150, 160, 170, 178, 188, 198, 208) sts. Work even in St st for 2", end on WS.

Dec Row (RS): K1, k2tog, knit to last 3 sts, SSK, k1—2 sts dec'd. Rep Dec Row every 1" 5 times more—108 (118, 128, 138, 148, 158, 166, 176, 186, 196) sts. Work even until piece measures 9" from beginning, end on WS.

Inc Row (RS): K1, M1k, knit to last stitch, M1k, k1—2 sts inc'd. Rep Inc Row every ½" 5 times more—120 (130, 140, 150, 160, 170, 178, 188, 198, 208) sts. Work even until piece measures 13" from beginning, end on WS.

Shape Armholes: Cast on 5 sts at beginning of the next 2 rows—130 (140, 150, 160, 170, 180, 188, 198, 208, 218) sts. Mark beginning and end of last row. Work even until armholes measure 7 (7, 7½, 7½, 8, 8, 8½, 8½, 9, 9)" above markers, end on WS.

Shape Shoulders: Bind off 2 (3, 3, 3, 4, 4, 5, 5, 5, 6) sts at beginning of the next 8 (18, 12, 2, 16, 6, 18, 12, 2, 16) rows, then 3 (0, 4, 4, 5, 5, 0, 6, 6, 7) sts at beginning of the next 10 (0, 6, 16, 2, 12, 0, 6, 16, 2) rows, end on WS—84 (86, 90, 90, 96, 96, 98, 102, 102, 108) sts. Mark center 62 sts on last row with 11 (12, 14, 14, 17, 17, 18, 20, 20, 23) sts on each side.

Shape Neck: Next Row (RS): Bind off 3 (3, 4, 4, 5, 5, 5, 6, 6, 7) sts, knit to marker, slip 8 (9, 10, 10, 12, 12, 13, 14, 14, 16) sts just worked onto waste yarn for right side; bind off 62 sts, removing markers, knit to end—11 (12, 14, 14, 17, 17, 18, 20, 20, 23) sts.

Left Side: Next Row (WS): Bind off 3 (3, 4, 4, 5, 5, 5, 6, 6, 7) sts, purl to end—8 (9, 10, 10, 12, 12, 13, 14, 14, 16) sts. Dec 1 st at beginning of the next row, then at the beginning of every RS row once more. AT THE SAME TIME, bind off 3 (3, 4, 4, 5, 5, 5, 6, 6, 7) sts at armhole edge 2 (1, 2, 2, 2, 1, 2, 2, 2) time(s) more, then 0 (4, 0, 0, 0, 0, 6, 0, 0, 0) sts once more for shoulder. Fasten off.

Right Side: With WS facing, slip 8 (9, 10, 10, 12, 12, 13, 14, 14, 16) sts from waste yarn to straight needle. Join MC and purl 1 WS row. Dec 1 st at end of the next RS row, then at end of every RS row once more. AT THE SAME TIME, bind



off 3 (3, 4, 4, 5, 5, 6, 6, 7) sts at armhole edge 2 (1, 2, 2, 2, 2, 1, 2, 2, 2) time(s) more, then 0 (4, 0, 0, 0, 6, 0, 0, 0) sts once more for shoulder. Fasten off.

FRONT

Work as for back until armholes measure 1 (1, 1½, 1½, 2, 2, 2½, 2½, 3, 3)", end on WS—130 (140, 150, 160, 170, 180, 188, 198, 208, 218) sts.

Shape Neck: Next Row (RS): K65 (70, 75, 80, 85, 90, 94, 99, 104, 109), slip stitches just worked to holder for left side, knit to end—65 (70, 75, 80, 85, 90, 94, 99, 104, 109) sts.

Right Side: Purl 1 WS row.

Dec Row (RS): K1, k2tog, knit to end – 1 st dec'd. Rep Dec Row every RS row 32 times more. AT THE SAME TIME, when armhole measures 7 (7, 7½, 7½, 8, 8, 8½, 8½, 9, 9)", (before all neck decs have been completed), end on RS. Continuing to rep Dec Row as before, bind off 2 (3, 3, 3, 4, 4, 5, 5, 5, 6) sts at beginning of the next 4 (11, 6, 1, 8, 3, 11, 6, 1, 8) WS rows, then 3 (4, 4, 4, 5, 5, 6, 6, 6, 7) sts at beginning of the next 8 (1, 6, 11, 4, 9, 1, 6, 11, 4) WS rows for shoulder.

Left Side: With WS facing, slip 65 (70, 75, 80, 85, 90, 94, 99, 104, 109) sts from holder to straight needle. Join yarn and purl 1 row, knit 1 row, purl 1 row.

Dec Row (RS): Knit to last 3 sts, SSK, k1 – 1 st dec'd. Rep Dec Row every RS row 32 times more. AT THE SAME TIME, when armhole measures 7 (7, 7½, 7½, 8, 8, 8½, 8½, 9, 9)", (before all neck decs have been completed), end on WS. Continuing to rep Dec Row as before, bind off 2 (3, 3, 3, 4, 4, 5, 5, 5, 6) sts at beginning of the next 4 (11, 6, 1, 8, 3, 11, 6, 1, 8) WS rows, then 3 (4, 4, 4, 5, 5, 6, 6, 6, 7) sts at beginning of the next 8 (1, 6, 11, 4, 9, 1, 6, 11, 4) WS rows for shoulder. Sew shoulder seams.

SLEEVES

With straight needles, using CC, pick up and knit 84 (84, 90, 90, 96, 96, 102, 102, 108, 108) sts along entire armhole edge. Beginning with a purl row, work even in St st for 1", end on WS.

Dec Row (RS): K1, k2tog, knit to the last 3 sts, SSK, k1—2 sts dec'd. Rep Dec Row every 8th (8th, 6th, 6th, 6th, 6th, 6th, 6th, 4th, 4th) row 14 (14, 17, 17, 19, 19, 20, 20, 23, 23) times more—54 (54, 54, 54, 56, 56, 60, 60, 60, 60) sts. Work even until sleeve measures 18" from beginning, end on WS. Bind off.



FINISHING

Sew side and sleeve seams.

Neck Edging: Applied I-Cord: With RS facing, using circular needle and MC, begin at left shoulder seam, pick up and knit 51 sts along left front neck edge, 51 sts along right front neck edge, then 56 sts across back neck edge—158 sts. Break off yarn, leaving sts on circular needle. With dpns and MC, using provisional cast-on, cast on 4 sts.

Row 1 (RS): K3, sl first stitch from circular needle to dpn and k2tog. DO NOT turn. Slide stitches to beginning of dpn to work next row from RS. Rep Row 1 until all stitches on circular needle have been used. Unravel provisional cast-on, slipping stitches to second dpn and weave stitches together using Kitchener St.

Weave in all ends and block as desired.

CAMBRIDGE SCHEMATIC

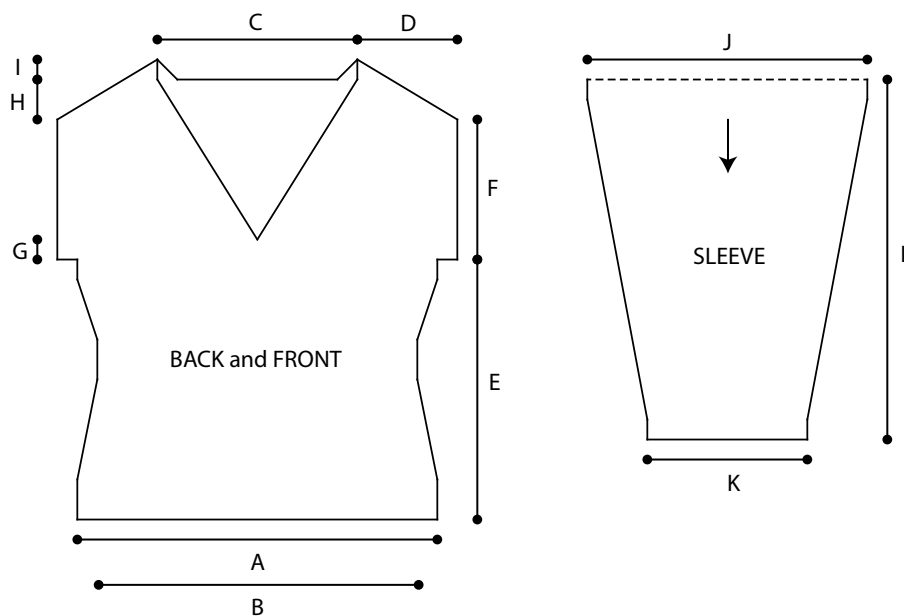

CAMBRIDGE MEASUREMENTS

A (Back and Front Width): 18½ (20, 21½, 23, 24½, 26, 27½, 29, 30½, 32)"

B (Back and Front Waist): 16½ (18, 19½, 21¼, 22¾, 24¼, 25½, 27, 28½, 30)"

C (Neck Width): 10"

D (Shoulder Width): 5 (5½, 6½, 7¼, 8, 8¾, 9¼, 10, 10¾, 11½)"

E (Length to Armholes): 13"

F (Armholes): 7 (7, 7½, 7½, 8, 8, 8½, 8½, 9, 9)"

G (Armhole to Neck): 1 (1, 1½, 1½, 2, 2, 2½, 2½, 3, 3)"

H (Shoulder Depth): 3"

I (Back Neck Depth): 1"

J (Sleeve Width): 14 (14, 15, 15, 16, 16, 17, 17, 18, 18)"

K (Cuff Width): 9 (9, 9, 9, 9½, 9½, 10, 10, 10, 10)"

L (Sleeve Length): 18"

STANDARD ABBREVIATIONS & TERMS

beg: beginning

CC: contrasting color

ch: chain

cn: cable needle

dc: double crochet

dec: decrease

dpn(s): double-pointed needle(s)

end on WS: end having just completed a Wrong Side row.

end on RS: end having just completed a Right Side row

inc: increase

k: knit

k2tog: knit 2 stitches together (1 st inc'd)

kfb: knit in the front and back of next stitch

M1L: Make 1—Pick up horizontal strand between stitch just worked and next stitch from front to back, place on left hand needle, knit this stitch through the back (1 stitch increased).

M1pL: Make 1 purl—Pick up horizontal strand between stitch just worked and next stitch from front to back, place on left hand needle, purl this stitch through the back (1 stitch increased).

M1pR: Make 1 purl Right—Pick up horizontal strand between stitch just worked and next stitch from back to front, place on left hand needle, purl this stitch through the front (1 stitch increased).

M1R: Make 1 Right—Pick up horizontal strand between stitch just worked and next stitch from back to front, place on left hand needle, knit this stitch through the front (1 stitch increased).

MC: main color

p: purl

p2tog: purl 2 stitches together

pm: place marker

pssso: pass slipped stitch over

rep: repeat

Reverse St st: Purl 1 row, knit 1 row alternately when working back and forth in rows. The purl side is the right side of the work. Purl EVERY round when working in the round.

RH: right hand

RLI: Right Lifted Increase—Insert RH needle into the purl bump of the next st on the LH needle and knit into this st (1 st inc'd)

rnd(s): round(s)

RS: right side

sc: single crochet

sl: slip

sm: slip marker

sp: space

SSK: Slip 2 stitches knitwise, insert point of left hand needle through fronts of these 2 stitches and knit 2 together.

SSP: Slip 2 stitches knitwise, transfer these 2 stitches back to left hand needle, purl 2 together through the back loops.

st(s): stitch(es)

St st: Stockinette Stitch—Knit 1 row, purl 1 row alternately when working in rows. The knit side is the right side of work. Knit EVERY round when working in the round.

w&t: wrap and turn, a method of concealing a hole created in short row shaping. On RS rows: With yarn held in front, slip next stitch purlwise, then bring yarn between needles to the back. Slip that same stitch back to the left needle. Turn your work. On WS Rows: With yarn held in back, slip next stitch purlwise, then bring yarn between needles to the front. Slip that same stitch back to the left needle. Turn your work. Unless otherwise indicated, each time you come to a wrapped stitch when working subsequent rows, slip the wrap back over stitch and onto needle, then work the wrap together with its accompanying stitch.

WS: wrong side

yo: yarn over

Love Berroco patterns?
Sign up for our **KnitBits®** newsletter.

